

> Arcserve **UDP** 8300 and **UDP** 8400
Appliance Hardware Installation Guide



Table of Contents

Section 1	Safety Notice and Warnings	3
Section 2	Ratings	3
Section 3	Electrical and General Safety Guidelines	4
Section 4	Site Preparation	6
Section 5	Unpacking the Appliance	7
Section 6A	4-Post Rack Installation (square holes)	8
Section 6B	4-Post Rack Installation (round holes)	9
Section 7	Rail Installation on the Appliance	10
Section 8	Installing the Appliance in the Rack	11
Section 9	Rear Panel Connections	12
Section 10	Cabling the Appliance	13
Section 11	Front Panel Connections	14
Section 12	Bezel Installation on the Appliance	15
Section 13	Run Arcserve UDP Appliance Wizard	15
Section 14	Access Arcserve UDP	16
Section 15	Contact Support	16
Section 16	Warranty Information	16

1. Safety Notice and Warnings

FCC Notice

This device complies with part 15 of the FCC Rules. Operation is subject to the following two conditions:

1. This device may not cause harmful interference.
2. This device must accept any interference received, including interference that may cause undesired operation.

No Telecommunications Network Voltage (TNV)-connected PCBs shall be installed.

CAN ICES-3 (A)/NMB-3(A)

CE Mark Warning

This is a Class A product. In a domestic environment, this product may cause radio interference, in which case the user may be required to take adequate measures.

VCCI Warning

This is a product of VCCI Class A Compliance.

この装置は、クラスA情報技術装置です。この装置を家庭環境で使用すると電波妨害を引き起こすことがあります。この場合には使用者が適切な対策を講ずるよう要求されることがあります。 VCCI-A

Environmental Warning

Perchlorate Material - special handling may apply. See www.dtsc.ca.gov/hazardouswaste/perchlorate.

This notice is required by California Code of Regulations, Title 22, Division 4.5, Chapter 33: Best Management Practices for Perchlorate Materials. This product/part includes a battery that contains perchlorate material.

2. Ratings

AC input rating: 100-240 V, 11-4.4 Amp

Rated input frequency: 50-60 Hz

With power distributor:
 +5V: 45 Amp
 +3.3V: 24 Amp
 -12V: 0.6 Amp

Base weight: 52 lbs (23.6kg). This weight may be more depending on the addition of devices such as hard disk drives, PCI circuit boards, etc.

3. Electrical and General Safety Guidelines



CAUTION

This appliance is intended for installation in restricted areas only. Initial setup and maintenance should be performed by qualified personnel.



CAUTION

Power down the appliance following the operating system's proper power down procedure from the front panel. Unplug the AC power cord(s) before servicing.



CAUTION

To avoid electrical shock, check the power cords as follows:

- This product is to be installed in Restricted Access Location only.
- Use the exact type of power cords required.
- Use power cord(s) that came with safety certifications.
- Power cord(s) must comply with AC voltage requirements in your region.
- The power cord plug cap must have an electrical current rating that is at least 125% of the electrical current rating of this product.
- The power cord plug cap that plugs into the AC receptacle on the power supply must be an IEC 320, sheet C13, type female connector.
- Plug the power cord(s) into a socket that is properly grounded before turning on the power.



CAUTION

Required operating conditions for the appliance are -

- Temperature: 10 to 35°C.
- Humidity, non-condensing: 8 to 90%.



CAUTION

CLASS 1 LASER PRODUCT
APPAREIL À LASER DE CLASSE 1

DISPOSING OF BATTERY BACKUP UNITS - IF APPLICABLE



WARNING

If the BBU is damaged in any way, toxic chemicals may be released.

The material in the battery pack contains heavy metals that can contaminate the environment. Federal, state, and local regulations prohibit the disposal of rechargeable batteries in public landfills. Be sure to recycle the old battery packs properly. Comply with all applicable battery disposal and hazardous material handling laws and regulations in the country or other jurisdiction where you are using the BBU.



WARNING

Risk of explosion if the battery is installed upside down or is replaced by an incorrect type.

Replace it only with the same or equivalent type recommended by the manufacturer. Dispose of used batteries according to the instructions.

3. Electrical and General Safety Guidelines (continued)



WARNING

Disconnect the power supply at the circuit breaker before accessing any components. Turning off the system power supply switch does not reduce the risk of electrical shock from the power supply terminal block.



CAUTION

- To prevent the unit from overheating, never install the appliance in an enclosed area that is not properly ventilated or cooled. For proper airflow, keep the front and back sides of the appliance clear of obstructions and away from the exhaust of other equipment.
- Be aware of the locations of the power switches on the chassis and in the room, so you can disconnect the power supply if an accident occurs.
- Take extra precautionary measures when working with high voltage components. Do not work alone.
- Before removing or installing main system components, be sure to disconnect the power first. Turn off the system before you disconnect the power supply.
- Use only one hand when working with powered-on electrical equipment to avoid possible electrical shock.
- Use rubber mats specifically designed as electrical insulators when working with computer systems.
- The power supply or power cord must include a grounding plug and must be plugged into grounded outlets.



CAUTION

Electric Static Discharge (ESD) can damage electronic components. To prevent damage to your system board, it is important to handle it very carefully. The following measures can prevent ESD damage to critical components.

- Use a grounded wrist strap designed to prevent static discharge.
- Keep all components and printed circuit boards (PCBs) in their antistatic bags until ready for use.
- Touch a grounded metal object before removing the board from the antistatic bag.
- Do not let components or PCBs come into contact with your clothing, which may retain a charge even if you are wearing a wrist strap.
- Handle a board by its edges only; do not touch its components, peripheral chips, memory modules or contacts.
- When handling chips or modules, avoid touching their pins.
- Put the motherboard and peripherals back into their antistatic bags when not in use.
- For grounding purposes, make sure your computer chassis provides excellent conductivity between the power supply, the case, the mounting fasteners and the motherboard.

4. Site Preparation

Setup location, rack and appliance precautions

- **Elevated Operating Ambient Temperature** - If installed in a closed or multi-unit rack assembly, the operating ambient temperature of the rack environment may be greater than room ambient temperature. Therefore, consideration should be given to installing the equipment in an environment compatible with the maximum ambient temperature (T_{ma}) specified by the manufacturer.

Always keep the rack's front door and all panels and components on the appliances closed when not servicing to maintain proper cooling.

- **Reduced Air Flow** - Installation of the equipment in a rack should be such that the amount of air flow required for safe operation of the equipment is not compromised. Leave enough clearance, approximately 25 inches in the front, and 30 inches in the back of the rack to enable you to access appliance components and allow for sufficient air flow.
- **Mechanical Loading** - Mounting of the equipment in the rack should be such that a hazardous condition is not achieved due to uneven mechanical loading.

ALL RACKS MUST BE MOUNTED SECURELY. Ensure that all leveling jacks or stabilizers are properly attached to the rack. If installing multiple appliances in a rack, make sure the overall loading for each branch circuit does not exceed the rated capacity.

Do not slide more than one appliance out from the rack at a time. Extending more than one appliance at a time may result in the rack becoming unstable. Install your appliance in the lower part of the rack because of its weight and also for ease in accessing appliance components.

- **Circuit Overloading** - Consideration should be given to the connection of the equipment to the supply circuit and the effect that overloading of the circuits might have on overcurrent protection and supply wiring. Appropriate consideration of equipment nameplate ratings should be used when addressing this concern.
- **Reliable Earthing** - Reliable earthing of rack-mounted equipment should be maintained. Particular attention should be given to supply connections other than direct connections to the branch circuit (e.g. use of power strips).
Install near appropriate AC outlets, and Ethernet hubs or individual jacks. Be sure to install an AC Power Disconnect for the entire rack assembly. The Power Disconnect must be clearly marked. Ground the rack assembly properly to avoid electrical shock.

5. Unpacking the Appliance

Before you begin, verify the ship kit includes the following installation hardware

- Two power cords
- 4-post rack mounting hardware (shown below)
- A pair of 2-post quick rail assemblies (shown below)

NOTE: Use the hardware supplied with your specific rack if different from the hardware supplied in this kit.

INSTALLATION HARDWARE

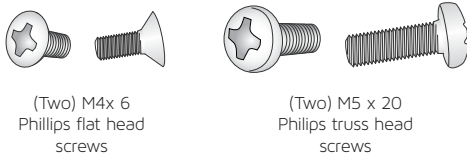

ALTERNATE INSTALLATION HARDWARE (Round Hole rack)

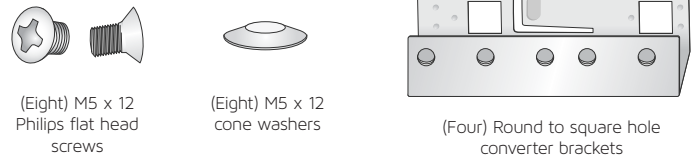

The 4-post (19-inch) quick rail assembly consists of:

- A pair of adjustable fixed, quick rack rail assemblies (including a sliding rack rail) that attach directly to the rack.
- A pair of inner fixed chassis rails that attach to the appliance (these must be removed from each of the quick rail assemblies).

Complete chassis and adjustable rack rail assembly (inside view)

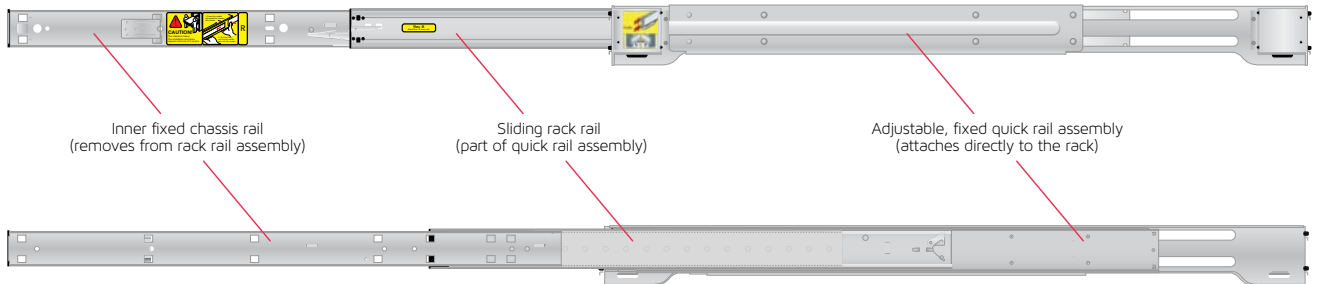

Complete chassis and adjustable rack rail assembly (outside view)

NOTE: The installation procedures for 6A, 4-Post Rack, below are for use with the rails and hardware provided in your ship kit. If different style rails are being used, or if your rack requires different hardware, refer to the instructions provided with your rail's or rack's ship kit.

6A. 4-Post Rack Installation (square holes)

Step 1

Locate the two adjustable standard rack rail assemblies.

- Remove the inner fixed chassis rails from the adjustable, quick rail assemblies
- Pull each inner fixed chassis rail out as far as possible. Press the locking tab down to pull the chassis rails completely out.
- Put these rails aside for later installation on the appliance.

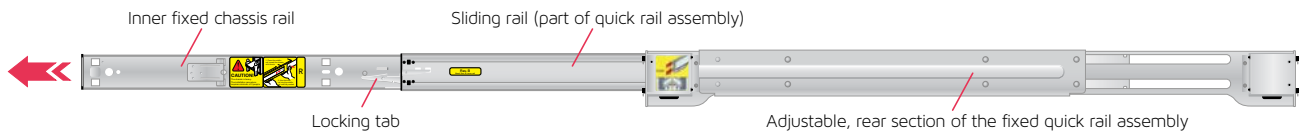

Step 2

- A** Attach a quick rail assembly in the front (on one side) of the rack. Insert the assembly hooks, with the hook facing down, through the openings in the rack. The release tabs secure the rails in place (as shown in the detail illustration on the right).
- B** Pull the adjustable rail assembly backward toward the back of the rack. The back section extends to adjust to the proper rack depth.*
- C** Insert the rear quick rail assembly hooks, with the hook facing down, through the openings in back of the rack.*

Attach the other adjustable, fixed, quick rail assembly to the rack following the steps **A** through **C** above.*

***NOTE:** Make sure the quick rail assemblies are aligned in the rack not only in the front and back, but are level in height on the left and right sides for proper alignment for appliance installation.

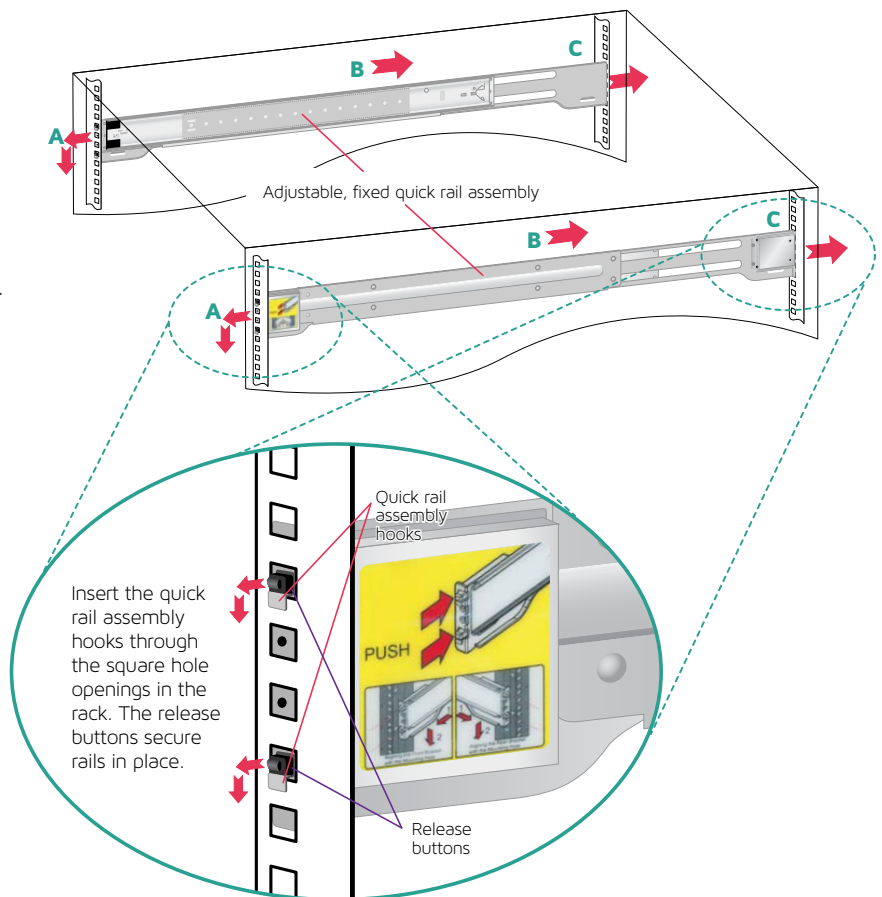

NOTE: The installation procedures for 6B, 4-Post Rack, below are for use with the rails and hardware provided in your ship kit. If different style rails are being used, or if your rack requires different hardware, refer to the instructions provided with your rail's or rack's ship kit.

6B. 4-Post Rack Installation (round holes)

Step 1

Locate the two adjustable standard rack rail assemblies.

- Remove the inner fixed chassis rails from the adjustable, quick rail assemblies
- Pull each inner fixed chassis rail out as far as possible. Press the locking tab down to pull the chassis rails completely out.
- Put these rails aside for later installation on the appliance.

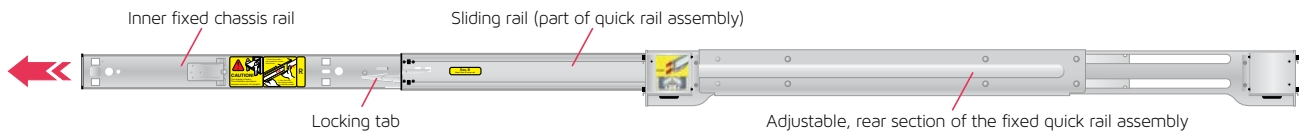

Step 2

- Install a square hole converter bracket in the front of the rack as shown in the detail illustration on the right using two M5 x 12 Phillips head screws and two M5 x 12 cone washers as shown in the detail illustration on the right.
- Repeat **A** to install a square hole converter bracket in the back of the rack using two M5 x 12 Phillips head screws and two M5 x 12 cone washers.*
- Attach a quick rail assembly in the front (on one side) of the rack. Insert the assembly hooks for the first quick rail as shown in the detail drawing below, with the hook facing down, through the openings in the square hole converter bracket. The release tabs secure the rails in place.
- Pull the adjustable rail assembly backward toward the back of the rack. The back section extends to adjust to the proper rack depth.
- Insert the back end of quick rail assembly hooks, with the hooks facing down, through the openings in square hole converter bracket. Make sure the rack rail assembly is level in the rack to allow for proper appliance installation later in this guide.
 - Follow steps **A** through **E** above to install the square hole converter brackets and rail assemblies on the other side of the rack.*

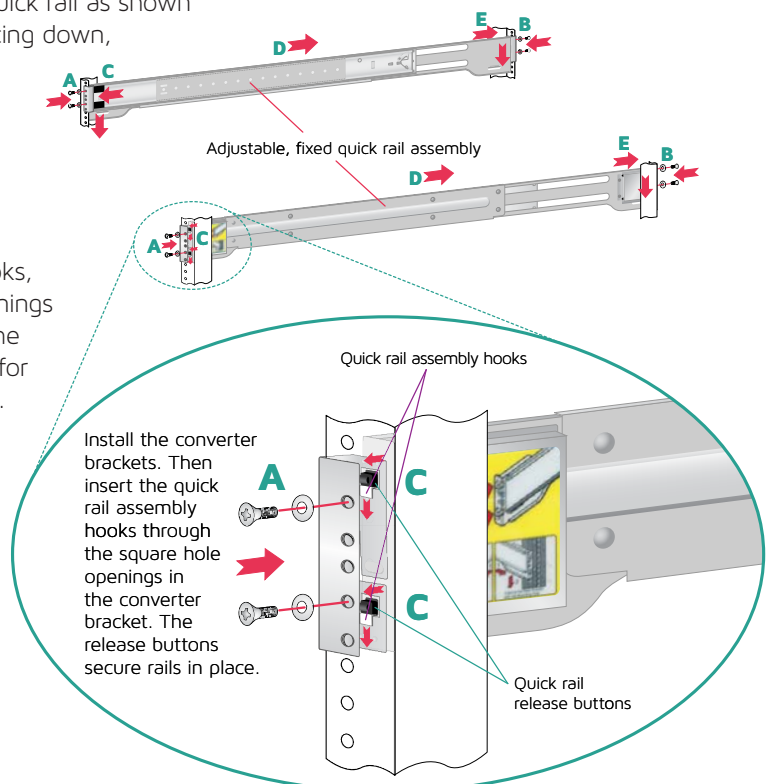
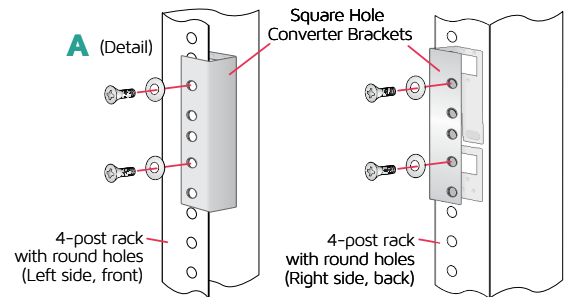

***NOTE:** Make sure the quick rail assemblies are aligned in the rack not only in the front and back, but are level in height on the left and right sides for proper alignment for appliance installation.

7. Rail Installation on the Appliance

Step 1

Locate the inner fixed chassis rails that were put aside in Step 1 on Page 8 or 9.

- Attach each inner fixed chassis rail to the appliance, as shown below, by sliding the rail openings under the top and bottom chassis rail tabs on each side of the appliance.

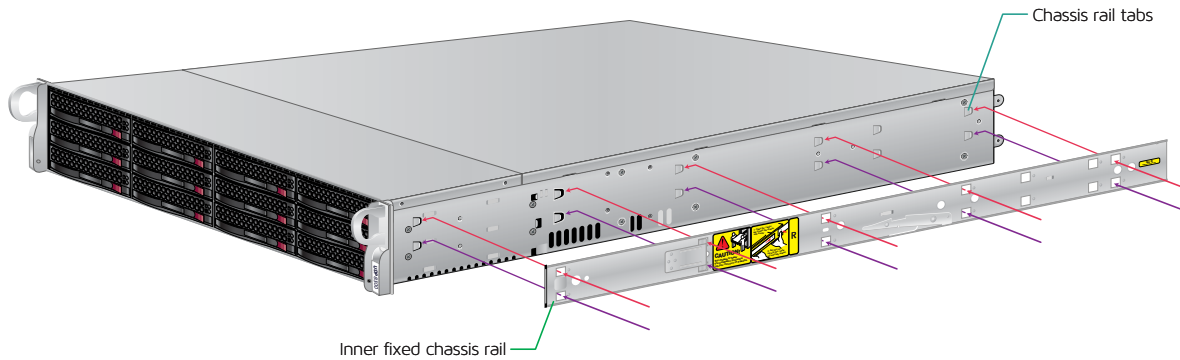

Step 2

- Check to make sure the chassis rail lock is holding the inner fixed chassis rails in place.
- Insert and tighten one M4 x 6 screw in the rear on each side as shown below.

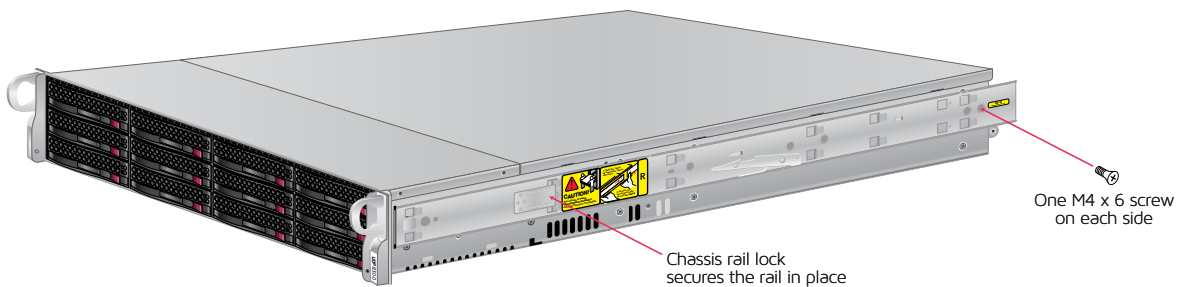

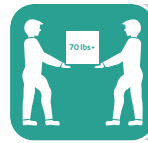

CAUTION

Use of a mechanical assistant to install and align server into the rack rails is required.

8. Installing the Appliance in the Rack

Step 1

- While supporting the appliance on the bottom, carefully align the back end of the fixed chassis rails on the appliance with the fixed adjustable rack rail assemblies previously installed in the rack.
- Carefully slide the appliance into the rack rails until you hear the locking tabs on the chassis rails click into place.

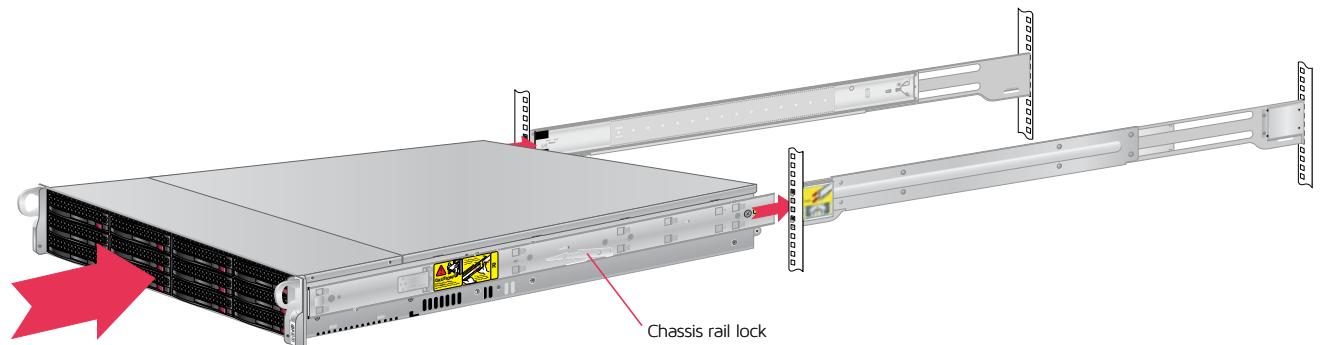

Step 2

- Push the appliance all the way into the rack until it stops.
- Secure the unit in the rack by inserting and tightening one M5 x 20 Phillips truss head screws* through the holes in the appliance handles as shown on each side.

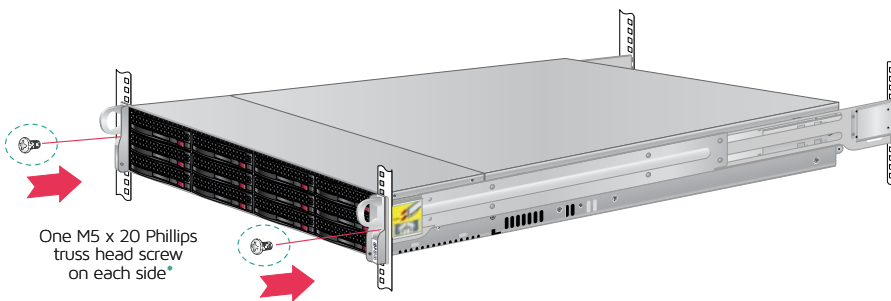

***NOTE:** Refer to your rack's mounting hardware for the proper size and type of screws to secure the appliance in the rack if different from the screws supplied in this ship kit.



CAUTION

Slide rail/mounted equipment is not to be used as a shelf or a work space.

9. Rear Panel Connections

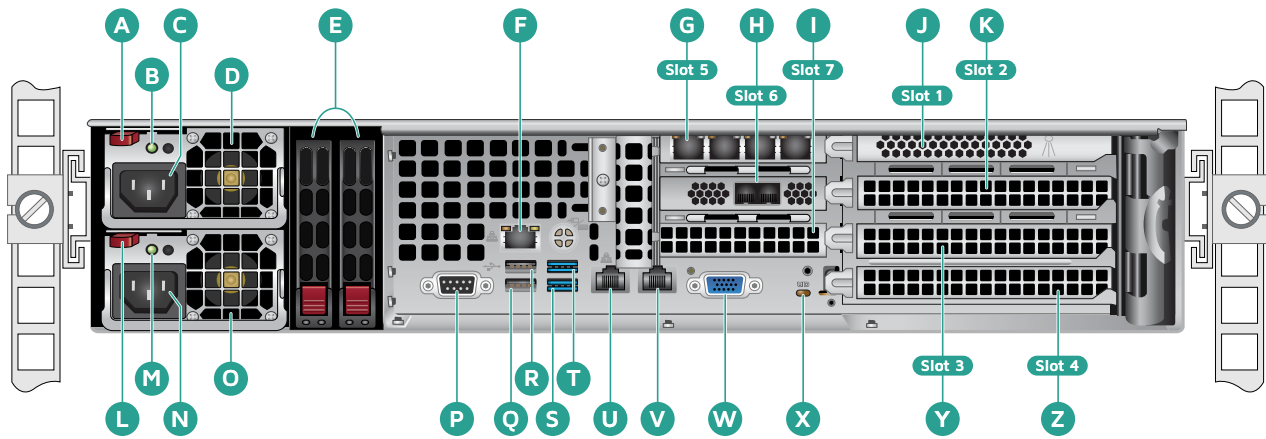

A	Power Supply Module #1 Lock	N	Power Supply Module #2 AC Receptacle
B	Power Supply Module #1 Power Good LED	O	Power Supply Module #1 Fan
C	Power Supply Module #1 AC Receptacle	P	COM Port
D	Power Supply Module #1 Fan	Q	USB Port 1 (generation 2)
E	Rear SSDs (optional)	R	USB Port 2 (generation 2)
F	IPMI Port (Remote Management)	S	USB Port 3 (generation 3)
G	Slot 5 Quad Port NIC Card	T	USB Port 4 (generation 3)
H	Slot 6 External SAS 9300 8e HBA Ports	U	ETH0 (Network 1)
I	Slot 7 Low Profile Non-PCIe Expansion Slot	V	ETH1 (Network 2)
J	Slot 1 LSI 9361-8i RAID Controller Card	W	VGA Port (Monitor)
K	Slot 2 Full Height PCIe Expansion Slot	X	UID LED
L	Power Supply Module #2 Lock	Y	Slot 3 Full Height PCIe Expansion Slot
M	Power Supply Module #2 Power Good LED	Z	Slot 4 Full Height PCIe Expansion Slot

PCI Card Slot Specifications

Card slot population options are as shown in the table below.

Slot 1	Slot 2	Slot 3	Slot 4
LSI 9361-8i RAID Controller (Always present in Slot 1)	Empty	Empty	Empty
	Dual Port 10G SPF+	Empty	Empty
	Dual Port 10G Copper	Empty	QLogic QLE2672 HBA
			Empty
			QLogic QLE2672 HBA
Slot 5	Slot 6	Slot 7	
Quad Port NIC (Always present in Slot 5)	SAS 9300-8e (Always present in Slot 6)	Empty	

10. Cabling the Appliance

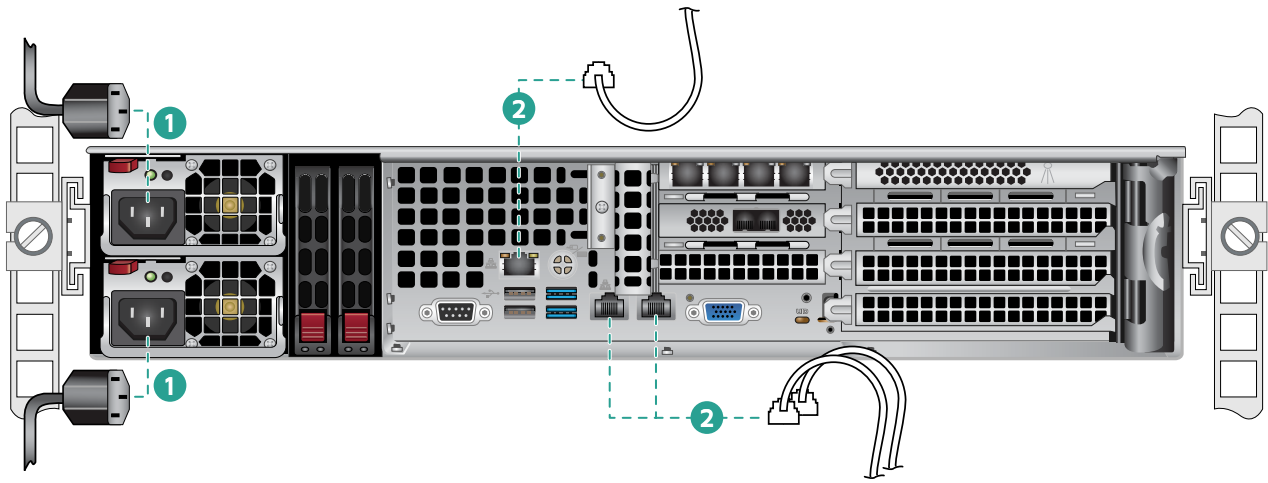

Step 1 Connect the power cord.

Step 2 Connect the Ethernet cables.

Step 3 Connect any other required cables.

Proceed to [Section 11, Front Panel Operation](#) on page 14.

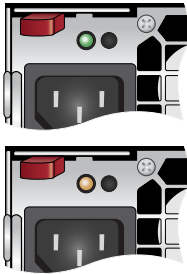

Power Supply Status LED

There is a single bi-color Power Good LED on each power supply module to indicate power supply status. The LED operation is defined in the table below.

Power Supply Condition

On the rear of the power supply module, an LED displays the status.

Solid Green: When illuminated, indicates that the power supply is on.

Solid Amber: When illuminated, indicates the power supply is plugged in and turned off, or the system is off but in an abnormal state.

Blinking Amber: When blinking, this system power supply temperature has reached 145°F (63°C). The system will automatically power-down when the power supply temperature reaches 158°F (70°C) and restarts when the power supply temperature goes below 140°F (60°C).

CAUTION

The power supply is hot-swappable only when you have a server with redundant power supplies installed. If you only have one power supply installed, before removing or replacing the power supply, you must first take the server out of service, turn off all peripheral devices connected to the server, turn off the server by pressing the power button, and unplug the AC power cord from the server or wall outlet.

NOTE: The server offers redundant, hot-swap capability. The connections to AC mains should be made in a manner appropriate to local code and consistent with customer power distribution with or without redundant sources.

11. Front Panel Operation

Power Button:

Press the power button to power the system on.

Reset Button:

Regardless of what state the appliance is in, or what applications are currently running, pressing this button will cause the appliance to re-boot. You will need a pen-like device to access the reset button.

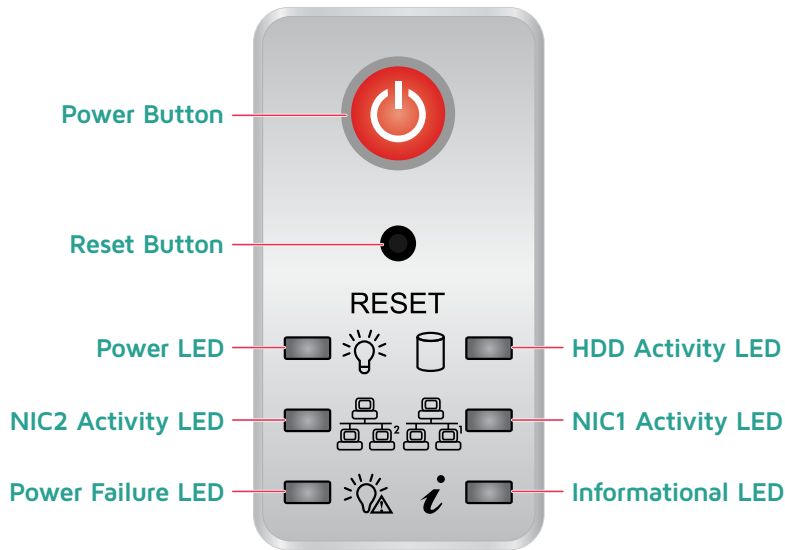

This LED alerts the operator of several states, as noted in the chart below.

Status	Description
Continuously on and red	An overheat condition has occurred. (May be due to cable congestion.)
Blinking red (1Hz)	Fan failure, check for inoperative fan
Blinking red (0.25 Hz)	Power failure, check for a non-operational power supply
Solid Blue	Local UID has been activated. Use this function to locate the server in a rack mount environment.
Blinking Blue	Remote UID is on. Use this function to identify the server from a remote location.

12. Bezel Installation on the Appliance

Step 1 Align the bezel with the front of the appliance. Insert the top and bottom bezel tabs on the right side of the bezel into the right handle on the appliance.

Step 2 Swing the left side of the bezel in toward the appliance. Press in on the bezel to engage the top and bottom bezel tabs on the left side of the bezel into the left handle on the appliance.



13. Run Arcserve UDP Appliance Wizard

➤ 1. When power is initially applied to the appliance, the Arcserve UDP Appliance Wizard is launched. Navigate through each page of the wizard. For more information about the wizard, see the Arcserve UDP Appliance User Guide (arcserve.com/udp-appliance-userguide) or view the video at: arcserve.com/udp-appliance-wizard-video.

Note: After selecting the Operating System language, a screen to enter Windows license may come up. Skip to **proceed here**, the OS is already licensed and activated.

The wizard lets you perform the following tasks:

- Define the Appliance host name.
- Specify LAN connections for the Appliance.
- Configure email and alert settings.
- Create protection plans. *A protection plan lets you define source nodes, backup destination, and configure a backup schedule.*

Upon completion of the wizard, Arcserve UDP launches the UDP console at the **dashboard** page.

14. Access Arcserve UDP

> Arcserve UDP is a comprehensive solution to protect complex IT environments. The source-side and global deduplication solution protects your data residing in various types of nodes such as Windows, Linux, and virtual machines on VMware ESX servers or Microsoft Hyper-V servers. You can back up data to either a local machine or a recovery point server. A recovery point server is a central server where backups from multiple sources are stored and can be globally deduplicated. For more information about Arcserve UDP, see the Knowledge Center at: arcserve.com/udp-knowledge-center.

Arcserve UDP provides the following capabilities:

- Back up the data to deduplication/non-deduplication data stores on recovery point servers
- Back up recovery points to tape
- Create virtual standby machines from backup data
- Replicate backup data to recovery point servers and remote recovery point servers
- Restore backup data and perform Bare Metal Recovery (BMR)
- Copy selected data backup files to a secondary backup location
- Configure and manage Arcserve High Availability (HA) for critical servers in your environment

15. Contact Support

If you encounter any issues with your appliance, please visit our Arcserve Support site to search our Knowledge Base for solutions to common problems or to get Live Support for immediate assistance (the serial number is located on rear of appliance) at: arcserve.com/support.

16. Warranty

Each Arcserve UDP 8000 series appliance comes with a 3-year hardware warranty. For detailed information about this warranty, please visit: arcserve.com/udp-appliance-warranty.

For more information on Arcserve, please visit arcserve.com, or call +1.844.639.6792

Copyright © 2016-2017 Arcserve (USA), LLC and its affiliates and subsidiaries. All rights reserved. All trademarks, trade names, service marks and logos referenced herein belong to their respective owners. This document is for your informational purposes only. Arcserve assumes no responsibility for the accuracy or completeness of the information. To the extent permitted by applicable law, Arcserve provides this document "as is" without warranty of any kind, including, without limitation, any implied warranties of merchantability, fitness for a particular purpose, or non-infringement. In no event will Arcserve be liable for any loss or damage, direct or indirect, from the use of this document, including, without limitation, lost profits, business interruption, goodwill or lost data, even if Arcserve is expressly advised in advance of the possibility of such damage.

